

CITY

SPEED
LIMIT
55

TEXAS
JPQ-543

485-GDC

DELAWARE
CD-6112

ILLINOIS
29-Y222

IOWA
9 32321

MISSOURI
UL 7-80

Mrs.
Ramey

NO
PARKING
ANY
TIME

TO
EAT...

STOSA
CUCINE

STOSA

-UNA FAMIGLIA ITALIANA- 50 ANNI DI STORIA E UNA SOLA GRANDE PASSIONE: LA CUCINA.

Da 50 anni produciamo solo cucine, create e prodotte per migliorare la vita di chi, ogni giorno, vive nello spazio più conviviale della casa. Progettiamo e realizziamo esclusivamente in Italia prodotti eccellenti nella qualità, realmente sostenibili per ogni famiglia italiana e per i giovani. Ecco perché una cucina Stosa nasce da valori autentici come impegno, onestà, rispetto e originalità. In Italia e in oltre 40 Paesi nel mondo, con un mercato in costante espansione. Impegno per dare il meglio di noi attraverso ogni singola cucina, direttamente a casa tua. Onestà per trasformare i nostri progetti in spazi di vita davvero sostenibili. Rispetto per la natura che ci circonda e per tutta la filiera produttiva. Originalità per essere sempre più competitivi nell'innovazione tecnologica e funzionale. È così che ogni giorno costruiamo le nostre cucine. Pensando a te.

STOSA, AN ITALIAN FAMILY. 50 YEARS OF HISTORY
AND ONE GREAT PASSION: KITCHENS.

For 50 years we've been producing only kitchens, designed and built for those who enjoy spending time in the most welcoming room in the home. Our products, designed and made entirely in Italy, stand out for their quality yet are affordable for Italian families and young people. Because a Stosa kitchen is based on authentic values like commitment, honesty, respect and originality - in Italy and a further 40 countries worldwide, with a constantly growing market. Commitment to offer our best in every single kitchen, directly in your own home. Honesty to turn our designs into truly sustainable living areas. Respect for the nature surrounding us and for the whole production chain. Originality to be more and more competitive with regards technological and practical innovation. That's how we build our kitchens every day. Thinking of you.



UNA CUCINA, TRE MODI DI ABITARE,
LA NUOVA CITY DI STOSA
INTERPRETATA NEGLI STILI:

One kitchen, three ways of living:
Stosa's new CITY interpreted in the styles:

VINTAGE
Glamour
ELEGANCE

**BENVENUTI
NELLA NUOVA
CUCINA CITY,
UN MIX DI ISPIRAZIONI
-VINTAGE-
IL DESIGN DEL PASSATO
IN CHIAVE
CONTEMPORANEA.
UNO STILE NON
CONVENZIONALE,
E CREATIVO.**

Welcome to the new City kitchen, a mix of inspirations - VINTAGE - design from the past with a contemporary take.
An unconventional, creative style.

A solid, decisive look, a kitchen that delights the eyes and is titillating to touch. Rough surfaces in Jeans oak, Brizzo oak,
White oak or Sand paired with metal and sheet metal furniture, never-before-seen finishes like slate cement that evoke an industrial-style atmosphere.

**CITY
VINTAGE**

UN'ESTETICA SOLIDA E DECISA, UNA CUCINA CAPACE DI OFFRIRE INTERESSANTI SENSAZIONI TATTILI E VISIVE. SUPERFICI IRREGOLARI IN ROVERE JEANS, ROVERE BRIZZO, ROVERE BIANCO O SABBIA ABBINATE AD ARREDI IN METALLO E LAMIERA, FINITURE INEDITE COME CEMENTO LAVAGNA CHE EVOCANO ATMOSFERE INDUSTRIAL STYLE.



name:	CITY VINTAGE
composition:	colors: ROVERE BRIZZO ROVERE BIANCO BRIZZO OAK / WHITE OAK
001	plus: TAVOLO AMICO ESTRAIBILE E GIREVOLE SCAFFALI/DISPENSA AMICO CAPPA IPE A ISOLA AMICO EXTENDABLE ROTATING TABLE AMICO SHELVES / PANTRY IPE ISLAND HOOD



**SPEED
LIMIT
55**

TEXAS JPQ-543 485-GDC CO-6112 29-Y222 97 32321 UL 7-843 9561 A GP-7503 NWN-817

Mrs. Ramey
NO PARKING ANY TIME
TO EAT...

CITY VINTAGE



Una composizione aperta sul living:
la penisola con tavolo “Amico”
estraibile girevole divide la zona
preparazione dalla zona - TV - per uno
spazio estremamente conviviale.
L’anta telaio City in rovere Brizzo è
protagonista per basi e pensili con
maniglia Naked MTA in finitura Peltro.
Si integrano con la cucina gli elementi
a giorno “Liberty” in lamiera che
svolgono la funzione di mensole.
Top e schiena in finitura Fenix nero.

A composition that opens onto the living room:
the peninsula with rotating extendable “Amico”
table divides the food preparation area from
the TV area for an extremely cozy space.
The City Brizzo oak framed door steals the spotlight
with its Pewter-finished bases and wall units with
Naked MTA handle.
The open sheet metal “Liberty” units that act as
shelves blend right in with the kitchen.
Black Fenix finish for the top and back.

CITY
VINTAGE
composizione 001



CITY VINTAGE



**- TAVOLO "AMICO" ESTRAIBILE GIREVOLE -
PRONTO A SVELARSI,
CON UN SEMPLICE TOCCO
UNA GRANDE SORPRESA.**

*- ROTATING EXTENDABLE "AMICO" TABLE -
READY TO POP OUT,
WITH JUST A TOUCH
A BIG SURPRISE.*

Movimentare, dilatare lo spazio, soluzioni flessibili come il TAVOLO "AMICO" ESTRAIBILE GIREVOLE che compare, riappare e ruota a seconda delle esigenze, studiato per aumentare la superficie operativa delle composizioni. Il piano del tavolo può essere in lamiera finitura Peltro o bianco opaco, le gambe sono dotate di ruote bloccanti. Un desiderio di continuità, la cucina si fonde con la zona living: base con cestoni e mensole in rovere bianco con schiena effetto "lavagna".

Move, open up the space, flexible solutions like the ROTATING EXTENDABLE "AMICO" TABLE that disappears and reappears whenever you need it, designed to increase the usable surface of the compositions. The tabletop comes in either Pewter or matt white-finished sheet metal; the legs are equipped with locking wheels. Seeking continuity, the kitchen blends with the living area: base units with drawers and shelves in white oak with "slate-effect" back panel.

**CITY
VINTAGE**
composizione 001





**- SCAFFALE/DISPENSA "AMICO" -
PER ORDINARE,
RIPORRE PIATTI, TOVAGLIE
E BICCHIERI... TUTTO DA MOSTRARE,
TUTTO FA STUPIRE COME
LE CUCINE DELLA TRADIZIONE.**

*- "AMICO" Shelf/Pantry -
for organising, putting away plates, tablecloths and glasses...
all to display, all impresses like the traditional kitchens.*

C'è più di un ingrediente segreto in City: la ricerca dei materiali e la creatività del design. Un progetto che declina materiali di tradizione in veste contemporanea. In questa composizione la cappa "Ipe" in lamiera, finitura Peltro, porta un tocco deciso di forte carattere. Lo scaffale/dispensa "Amico" in metallo rivisita gli anni '50 in chiave moderna per un "sapore vissuto".

There is more than one secret ingredient in City: choice materials and creative design. A design that works with traditional materials giving them a contemporary take. In this composition, the Pewter-finished sheet metal hood "Ipe" gives a decided touch with strong personality. The metal furniture Amico Shelf/Pantry is a modern twist on 1950's style, yielding a "lived-in" feel.





CITY VINTAGE

CITY
VINTAGE
composizione 001



CITY - VINTAGE

CITY
VINTAGE
composizione 002

name:	CITY VINTAGE
composition:	colors: ROVERE JEANS ROVERE SABBIA JEANS OAK / SAND OAK
002	

NELLA NUOVA
CUCINA CITY,
UN'ATMOSFERA LOFT
DAL GUSTO
-INDUSTRIAL CHIC-

In the new CITY kitchen, a loft atmosphere with an - INDUSTRIAL CHIC - feel.





La cucina diventa un luogo da vivere quotidianamente, uno spazio dedicato al lavoro, al divertimento e alla socializzazione. Un ambiente unico fatto di finiture calde e rassicuranti come il rovere Jeans e rovere Sabbia ed i pensili "Flute" in vetro con motivo Ondulina dal sapore retrò con maniglia MVAB. Top e alzatina in Okite grigio chiaro. Zoccolo in finitura piombo. Due elementi protagonisti: Scaffale/dispensa "Amico" e vetri acidati effetto Ondulina.

The kitchen becomes a place to work, have fun and socialise day in and day out. A unique environment made of warm, reassuring finishes like Jeans or Sand oak and wall units with a retrò Ondulina pattern with MVAB handle. Okite light grey top and cake stand. Toe-kicks in lead finish. Two important elements: the "Amico" shelf/pantry and the glass-etched Ondulina effect.



CITY
VINTAGE
 composizione 002





CITY
VINTAGE
composizione 002

CITY

VINTAGE

003

Design di stile metropolitano per City. Metalli effetto invecchiato e lamiera sono accostati alle naturali essenze rovere Jeans e rovere Brizzo per un nuovo modo di vestire la cucina. Le composizioni sono intervallate da accessori free-standing originali e unici come il carrello "Amico" in Peltro, la dispensa/scaffale "Amico" a vista in metallo e la grande cappa "Loft" che entrano in cucina come veri e propri oggetti di culto, intramontabili e dal fascino spiccato.

Metropolitan-style design for City. Antiqued metals and sheet metal are paired with natural Jeans wood types and Brizzo oak for a new way of sprucing up the kitchen. The compositions are broken up by original, unique free-standing accessories like the Pewter "Amico" cart, the open metal "Amico" pantry and the large Ipe hood that make their way into the kitchen like authentic cult items that never go out of style and are quite charming.



name:	CITY VINTAGE
composition:	colors: ROVERE JEANS ROVERE BRIZZO JEANS OAK / SAND OAK
003	plus: SCAFFALI/DISPENSA AMICO CARRELLO AMICO CAPPA LOFT AMICO SHELVES/PANTRY AMICO CART LOFT HOOD

CITY

VINTAGE

composizione 003





Unica tonalità il grigio in tutte le sue sfumature: top Fenix colore grigio Londra, maniglia Naked MTA in finitura Peltro e al centro della scena la grande cappa Loft che ricorda il fascino delle opere in ferro battuto dal vissuto unico, ispirati alla maestria artigianale.

Unique colour: all shades of grey: London grey Fenix top, Pewter-finished Naked MTA handle, and at centre stage, the large Loft hood reminiscent of the charm of works in wrought iron with a unique lived-in look, drawing inspiration from the mastery of artisans.

CITY
VINTAGE
composizione 003





CITY
VINTAGE
composizione 003

**OGNI
COSA
AL SUO
POSTO**

EVERYTHING IN ITS PLACE!



**CITY
VINTAGE**

composizione 003



**- ANTA VETRO ONDULINA -
IL VETRO HA UNA VIBRAZIONE PARTICOLARE
È UN MATERIALE SENZA TEMPO
DI GRANDE SUGGERIONE.**

*- ONDULINA GLASS DOOR -
the glass has a special shimmer;
it is a highly evocative, timeless material.*

Dinamicità in cucina con il carrello "Amico", struttura in metallo finitura Peltro con cassetto e ruote. Si adatta ad ogni situazione, è un complemento d'arredo versatile e giovane, disponibile nelle finiture Peltro e Bianco opaco.

Pizzazz in the kitchen with the Pewter-finished metal "Amico" cart with drawer and wheels. Suitable to any situation, it is a versatile furniture accessory with a young look available in Pewter and matte White finishes.





name: **CITY VINTAGE**

composition: colors: ROVERE JEANS
JEANS OAK

004 plus: GOLA, ZOCCOLO, VANI A
GIORNO IN METALLO COLORATO
COLOURFUL GROOVE, TOE-KICK
AND OPEN COMPARTMENTS

CITY VINTAGE composizione 004



tante soluzioni
10 COLORI

TITANIO / titanium

BRILL / brill

BIANCO / white

PIOMBO / lead

CORDA / cord

GIALLO / yellow

ARANCIO / orange

ROSSO / red

OLIVA / olive

ACQUAMARINA / aquamarine

**NOTE ACCESE DI COLORE PER LA
- GOLA SCAVATA E VANI A
GIORNO IN METALLO -**

*bright notes of colour for the
- HOLLOW GROOVE AND METAL COMPARTMENTS -*



Basta un tocco di colore per creare una cucina speciale. City propone un modo semplice e vivace per rompere gli schemi tradizionali: la gola scavata e i vani a giorno si possono personalizzare con 10 colori diversi, creando contrasti cromatici di forte effetto visivo.

All you need is a touch of colour to create a special kitchen. City offers an easy and lively way to break with traditional schemes: the hollow groove and open compartments can be customised with 10 different colours, creating high-impact colour contrasts.



CITY
VINTAGE

composizione 004

CITY

Glamour

composizione 005

City Glamour ariosa e luminosa, per uno stile di vita libero, spontaneo e naturale. Una ritmata modulazione tra rovere Jeans, rovere Bianco e ante effetto lavagna. Un'importante isola al centro dell'ambiente, soluzioni a parete, uno spazio aperto un pò kitchen e un pò living da vivere e condividere.

Airy and bright City Glamour, for a free, spontaneous and natural lifestyle.

A measured transition from Jeans oak, White oak to slate-effect doors.

An imposing island in the centre of the room, wall-hanging solutions, an open space that's a little bit kitchen and a little bit living room to experience and share.

* ANTE FINITURA - EFFETTO LAVAGNA -

Le ante dei pensili si possono anche disegnare e cancellare come una vecchia lavagna di scuola. Ogni giorno una storia da raccontare.

DOORS FINISHED WITH SLATE EFFECT.
The doors of the wall units can also draw on and erased just like the old classroom blackboards. A story to tell each day.



name:	CITY GLAMOUR
composition:	colors: ROVERE JEANS ROVERE BIANCO JEANS OAK / WHITE OAK
005	plus: ANTE LAVAGNA SLATE DOORS

CITY - GLAMOUR

CITY Glamour

composizione 005

*
**PARETE
 MAGNETICA**
 Attrezzature, mensole
 e le calamite colorate per gli
 appunti e i promemoria.
 Tutto si attacca, si sposta si
 riattacca...
 MAGNETIC WALL
 Equipment, shelves and coloured magnets
 for notes and memos. You can stick on, move
 or restick anything...

Le cucine Stosa sono belle ma
 anche funzionali grazie alla scelta di
 elettrodomestici tecnologicamente avanzati,
 in grado di dare il massimo sotto il profilo
 di efficienza e affidabilità. Prestazioni
 elevate e grande impatto visivo, cappe,
 piani cottura, forni... elettrodomestici
 stilisticamente perfetti che soddisfano le
 richieste anche dello chef più esigente.

Stosa kitchens are beautiful but
 functional thanks to the choice
 of advanced technology electrical
 appliances that yield maximum efficiency
 and reliability. Eyepopping, high-
 performance hoods, cooking ranges,
 ovens... stylistically perfect electrical
 appliances that meet the needs of even
 the most demanding chefs.



CITY *Glamour*
 composizione 005





CITY

CITY *Glamour*
composizione 005

CITY *Glamour* composizione 006

City Glamour in versione lineare si fa riconoscere.
Conserva tutto il suo fascino grazie al perfetto
gioco di volumi che si viene a creare
tra la cappa Ipe dal forte gusto Industrial
e le ante in vetro Ondulina
con il loro particolare effetto satinato.

City Glamour in the linear version makes itself known.
Keeps all its charm thanks to the perfect
volumes-play that is created
between the strong Industrial style of the hood Ipe
and the Ondulina glass doors
with their particular satin effect.



31
MILANO

name: CITY GLAMOUR

composition: colors: ROVERE BRIZZO
BRIZZO OAK

006 plus: CAPP A IPE
IPE HOOD

CITY *Glamour*
composizione 006

7 CITY */ELEGANCE*

Volumi essenziali, superfici con lavorazioni esclusive e ricercati abbinamenti tra materiali e finiture che disegnano con eleganza lo spazio domestico. City nella versione - elegance - in rovere Sabbia e laccato verde Oliva, si caratterizza per i dettagli esclusivi: gola scavata e zoccolo colorati in tinta.

Essential shapes, surfaces with exclusive workings and refined matching of materials and finishes that elegantly design the home.
City in the - elegance version - in Sand oak or Olive green lacquer, it is characterised by exclusive details: hollow groove and toe-kick in matching colour.



name:	CITY ELEGANCE
composition:	colors: ROVERE SABBIA SAND OAK
007	plus: GOLA SCAVATA COLORATA SCHIENALE IN VETRO LUMINOSO BIANCO METAL COLOURED HOLLOW GROOVE GLASS BACK BRIGHT WHITE METAL

CITY
ELEGANCE

7

Suggerzioni luminose ed essenzialità progettuale. L'elegante schienale in vetro è luminoso, un elemento decorativo e funzionale con accessori magnetici come portaspezie, barra per appendere gli attrezzi della cucina... tutto a portata di mano... è ancora più facile cucinare.

Bright charm and an essential design. The elegant glass back panel is lighted a decorative and functional part. With magnetic accessories like spiceholders and a bar for hanging kitchen utensils... all at the tip of your fingers... cooking is even more convenient.

CITY - ELEGANCE



7 CITY /ELEGANCE

Ogni elemento funzionale è progettato nei minimi dettagli selezionando colori e materiali. La gola colorata, disponibile in 10 varianti colore, sottolinea il disegno essenziale e raffinato di questa cucina. Un'altra proposta che completa City è il pensile incassato a muro con anta telaio con vetro Ondulina. Una piacevole decorazione, un richiamo al passato, con ispirazioni classiche riproposte in chiave moderna.

Each functional element is designed down to the last detail with choice colours and materials. The coloured groove, available in 10 different colours, underscores the essential and refined design of this kitchen. Another idea that makes City complete is the unit built into the wall with framed door with Ondulina glass. A pleasant decoration that harks to the past inspired by the classics, but revamped with a modern take.

CITY
ELEGANCE

8

CITY - ELEGANCE

name:	CITY ELEGANCE
composition:	colors: ROVERE BRIZZO BRIZZO OAK
008	plus: NICCHIE PER ANGOLO IN METALLO COLORE PELTRO MANIGLIA AD INCASSO FINITURA PELTRO NICHE FOR CORNER METAL PEWTER COLOR INCORPORATED HANDLE PEWTER FINISH





City in rovere Brizzo e laccato diretto Frost opaco con pratica maniglia ad incasso MTBA dal puro gusto industrial. Soluzioni ad angolo che studiano nei dettagli l'organizzazione degli spazi, come il vano a giorno quadrato in finitura Peltro perfetto per riporre piccoli elettrodomestici, piatti o altro. In bella mostra per dare personalità in cucina la cappa diventa un elemento decorativo e non solo di servizio.

Brizzo oak or directly matt Frost varnished City with practical MTBA recessed handle of purely industrial taste. Corner solutions that meticulously organise spaces, like the Pewter-finished square open compartment where you can put small electrical appliances, plates and more. In plain sight to give personality to the kitchen, the hood becomes not just a cooking, but a decorative unit.



8 CITY /ELEGANCE



9
CITY
/ELEGANCE

name:	CITY ELEGANCE
composition:	colors: ROVERE BRIZZO ROVERE BIANCO BRIZZO OAK / WHITE OAK
009	plus: GOLA SCAVATA COLORATA CORDA CORD COLOURED HOLLOW GROOVE



CITY - ELEGANCE



9 CITY /ELEGANCE

Il gioco delle finiture rivela scenari dalle mille possibilità dove è facile trovare quella che più interpreta il proprio gusto. La gola è un segno grafico che traduce l'estetica in praticità.

The combination of the finishes reveals scenarios of a thousand possibilities, where it's easy to find what suits your personal taste. The groove is a graphic that translates aesthetics into practicality.



10 CITY /ELEGANCE

CITY - ELEGANCE

name: CITY ELEGANCE

composition: colors: ROVERE SABBIA
SAND OAK

010



Mescolare Abbinare Mixare

La ricerca di forme essenziali raggiunge il cuore della funzionalità in cucina. Materiali e finiture definiscono gli spazi in continua evoluzione.

The search for essential forms reaches the heart of the functionality in the kitchen.
Materials and finishes define constantly evolving spaces.

10
CITY
/ELEGANCE

CITY

ABACO DELLE COMPOSIZIONI / SCHEDULE OF THE COMPOSITIONS

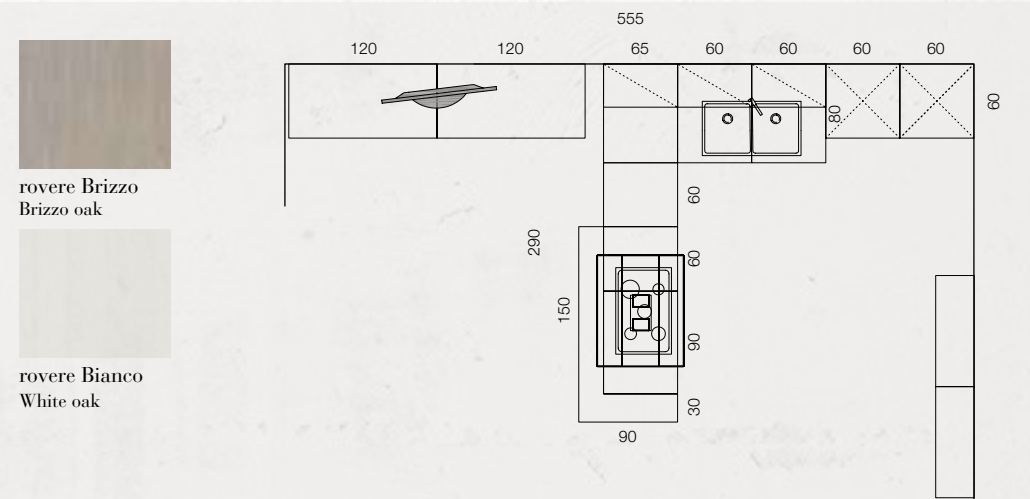

CITY
VINTAGE
composizione 001
page / 05

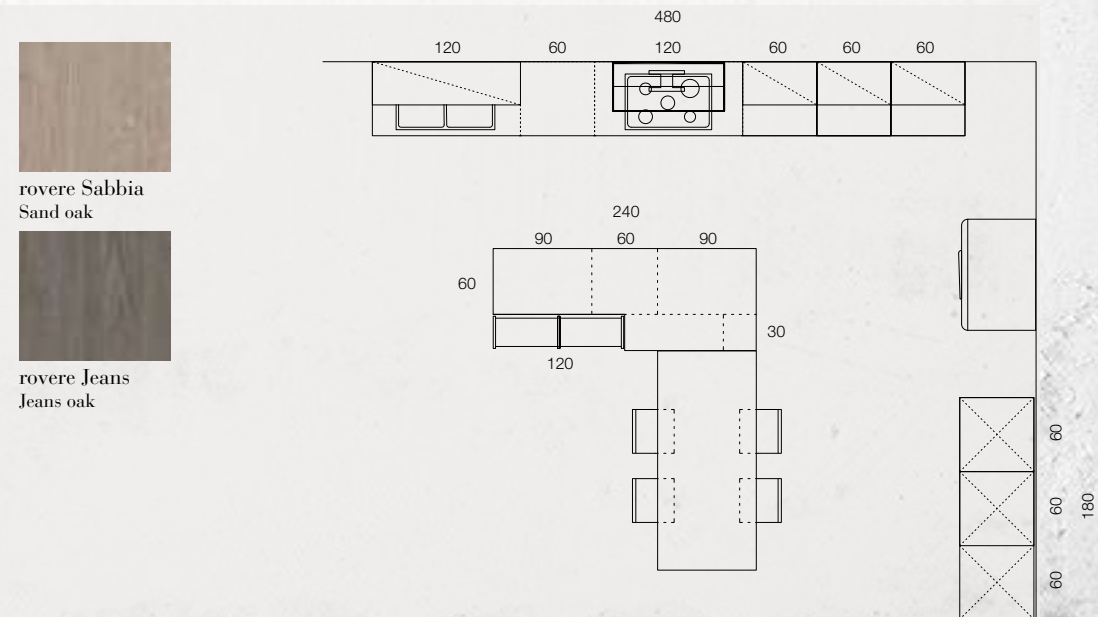

CITY
VINTAGE
composizione 002
page / 15

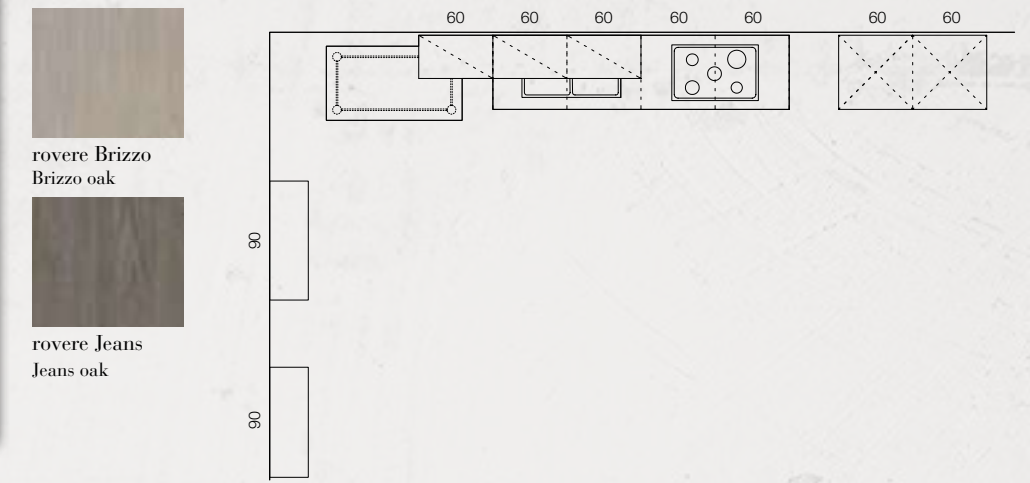

CITY
VINTAGE
composizione 003
page / 22

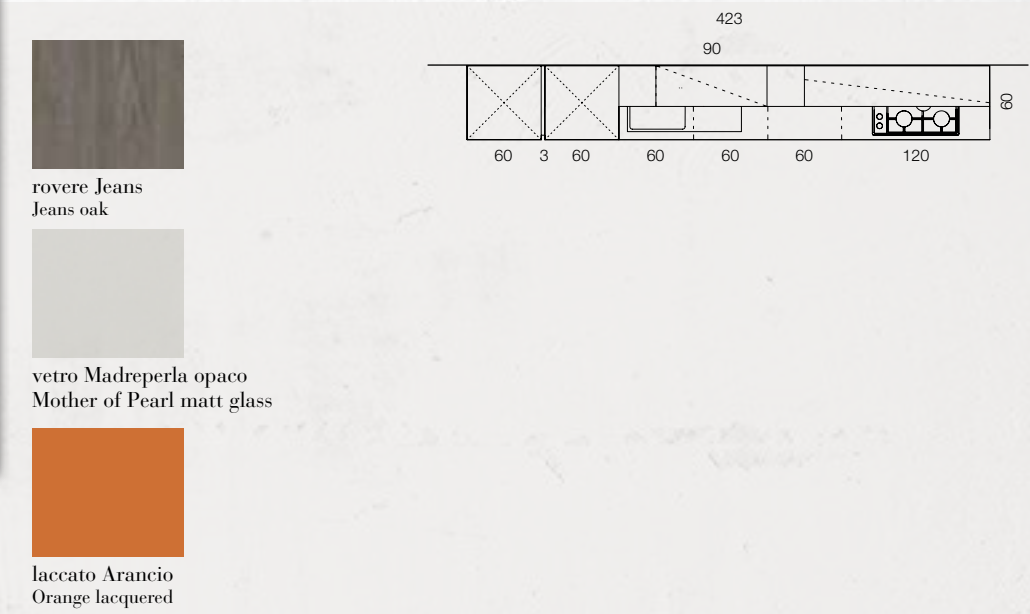

CITY
VINTAGE
composizione 004
page / 31

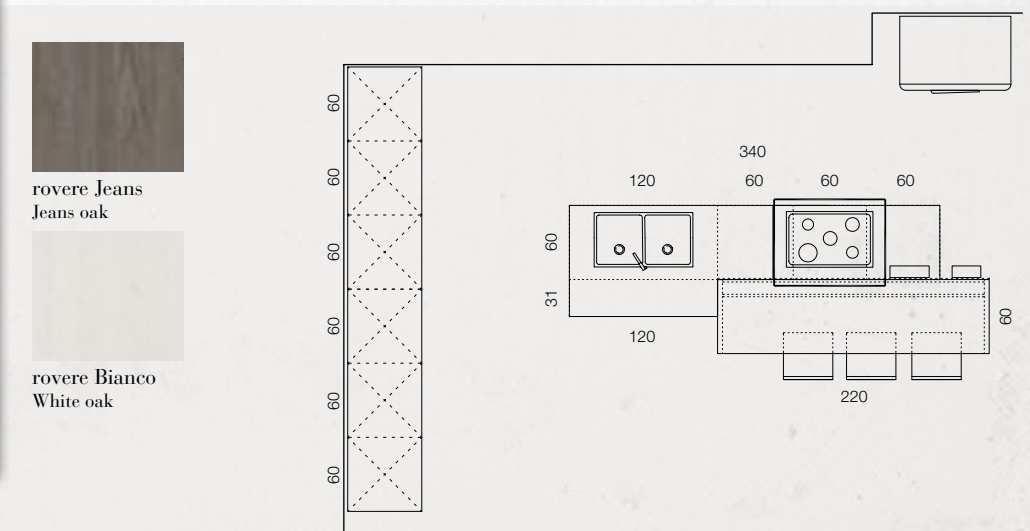

CITY
Glamour
composizione 005
page / 37

CITY

**ABACO
DELLE COMPOSIZIONI**
/ SCHEDULE OF THE COMPOSITIONS

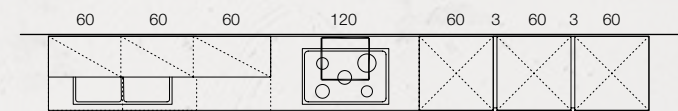

- rovere Brizzo
Brizzo oak
- laccato Peltro
Pewter lacquered

CITY
Glamour composizione 06
page / 45

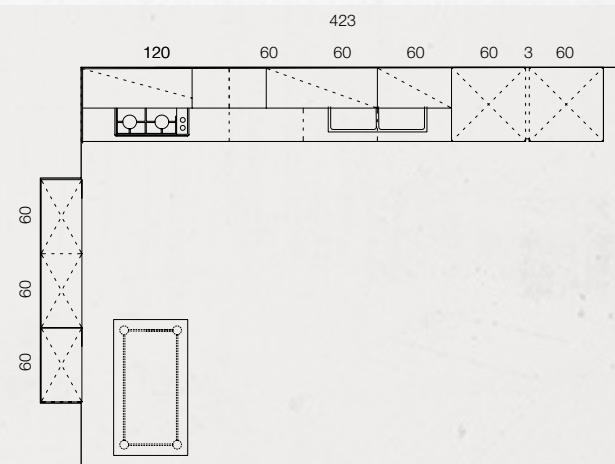

- rovere Sabbia
Sand oak
- laccato diretto
Oliva opaco
matt lacquered
direct Olive

CITY
ELEGANCE composizione 07
page / 49

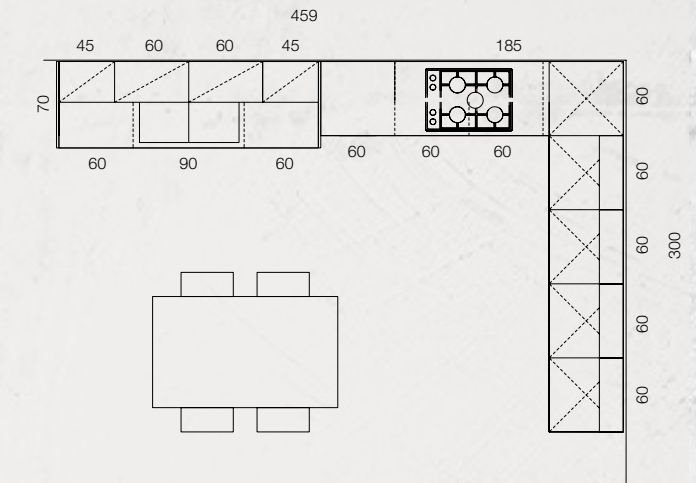

- rovere Brizzo
Brizzo oak
- laccato diretto
Frost opaco
matt lacquered
direct Frost

CITY
ELEGANCE composizione 08
page / 55

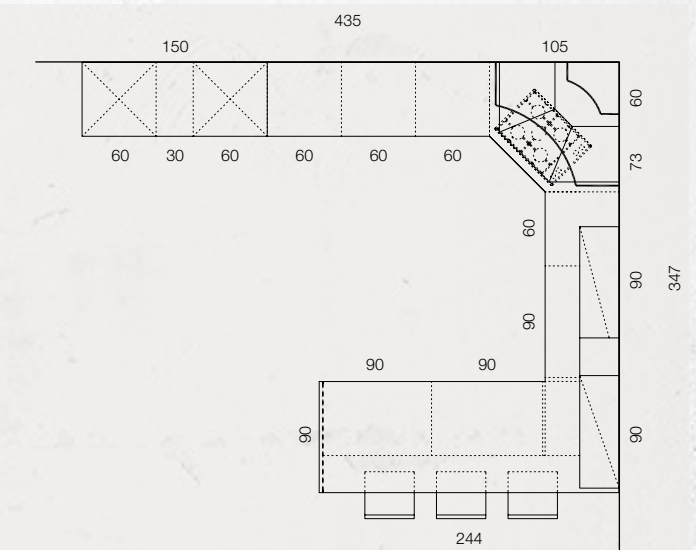

- rovere Brizzo
Brizzo oak
- rovere Bianco
White oak

CITY
ELEGANCE composizione 09
page / 59

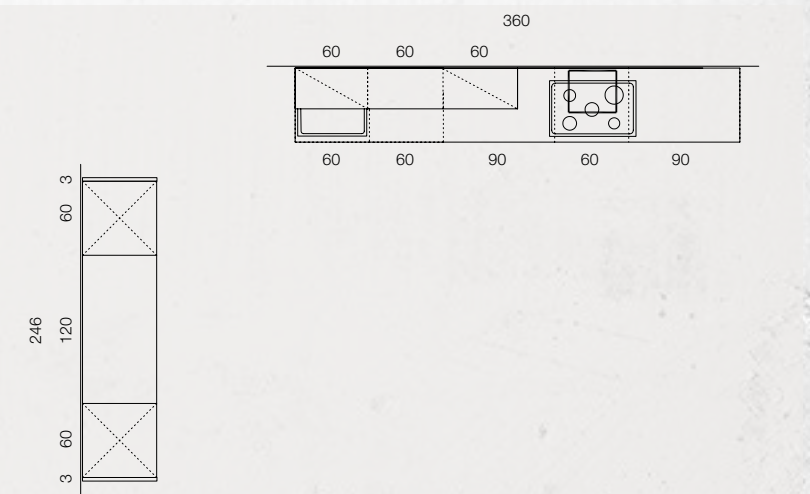

- rovere Sabbia
Sand oak
- laccato Peltro
Pewter lacquered
- laccato Corda
Cord lacquered

CITY
ELEGANCE composizione 10
page / 62

FINITURE / FINISHES



rovere Bianco / White oak



rovere Brizzo / Brizzo oak



rovere Jeans / Jeans oak



rovere Sabbia / Sand oak

MANIGLIE / HANDLES



NAKED _ MTA



MYAB



MTAB

GOLA / GROOVE



GOLA PIATTA CON TASCA disponibile in 5 colori.
FLAT GROOVE WITH POCKET Available in 5 colors.



GOLA SCAVATA disponibile in 10 colori.
HOLLOW GROOVE available in 10 colors.

MAGGIOR SICUREZZA MAGGIOR STABILITÀ

MORE SAFETY MORE STABILITY



G* GRASS®

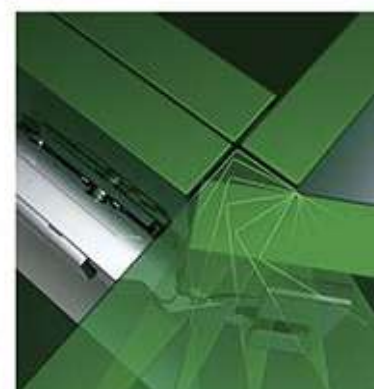

La tripla cerniera conferisce stabilità all'anta e maggior resistenza all'urto.

The triple hinge gives the door stability and greater resistance to slamming.

Stabilità costante in ogni posizione. Regolazione dell'altezza continua ed autobloccante.

Durable stability in every position. Stepless, self-locking height adjustment.

Con o senza frenata integrata. Stesso design per la combinazione di cerniere dotate e prive di Soft-close.

With or without integrated damping. Matching design for combinations of hinges with and without damping.

Maggiore comfort attraverso l'inno-vazione. Grazie al movimento della leva ottimizzato è possibile aprire le ante dei mobili in modo estremamente semplice.

Enhanced comfort thanks to new development. Optimised lever movement enables furniture doors to be opened with extreme ease.

Regolazione della frenata senza utensili. Chiusura uniforme indipendentemente dalle dimensioni e peso dell'anta.

Tool-free damper adjustment. Consistent closing action irrespective of door size and weight.

Design: Adriani e Rossi Edizioni
A. D. e Grafica: Adriani e Rossi Edizioni
Foto: Studio Indoor (Oderzo - TV)
Fotolito: Bieffe (VR)
Stampa: Eurotipo (VR)
Stampato in Italia Dicembre 2014



Kitchen Design Since 1964



VINTAGE
GLAMOUR
ELEGANCE

STOSA
CUCINE

STOSA S.P.A.

STAB., SEDE AMM.VA E RECAPITO POSTALE:
S.S. CASSIA, Km. 149,5
53040 RADICOFANI (SI) ITALY

GPS:
N 42° 53' 50,6"
E 11° 45' 53,5"

INFO:
TEL. +39 0578 5711 R.A.
FAX +39 0578 50088

INFO LINE:
840 000 691

WWW.STOSA.IT

STOSA@STOSA.IT



MPA03228